

THIS DRAWING IS UNPUBLISHED. RELEASED FOR PUBLICATION, 19
 © COPYRIGHT 19 BY AMP INCORPORATED. ALL INTERNATIONAL RIGHTS RESERVED.

LOC	DIST	P	F	REVISIONS				
G	14			ZONE	LTR	DESCRIPTION	DATE	APPD
					F	REV / 0L20-0025-97	28JAN97	ME TM

AMP WIRE RANGE	UL Listed	SR LR7189 Certified
22-16 AWG SOLID OR STRANDED	22-16 AWG SOLID OR STRANDED	22-16 AWG SOLID OR STRANDED

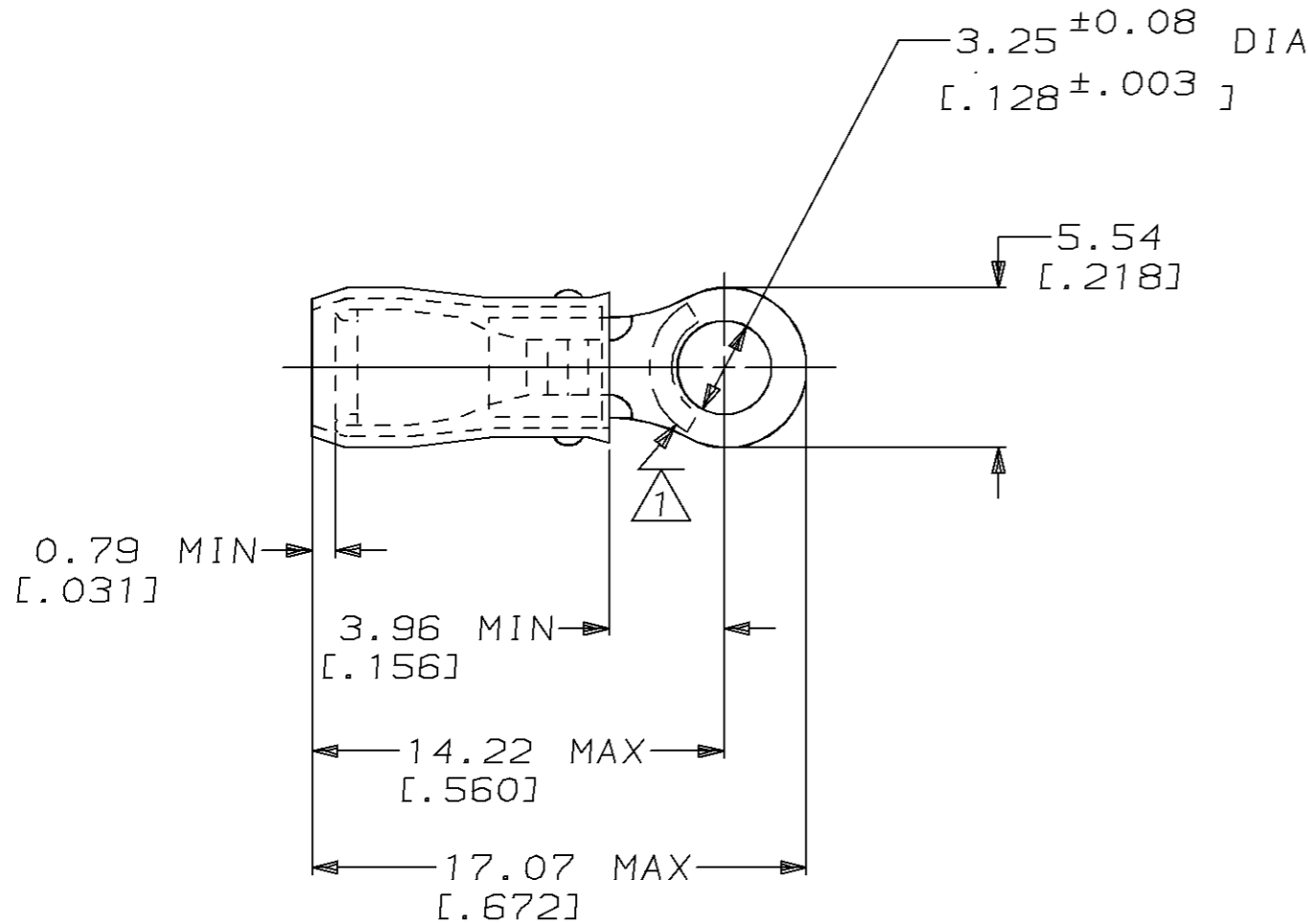

- 1 STAMP AMP 22-18* APPROX AS SHOWN
22-16 TERMINALS ARE STAMPED 22-18 IN
ACCORDANCE WITH MILITARY SPEC MIL-T-7928
COMMERCIAL WIRE RANGE IS 22-16
- 2 WIRE INSULATION DIA: .080 - .125
- 3 TONGUE MATERIAL THK: 0.79^{+0.05} [0.031^{+0.002}]

**AMP INCORPORATED
CUSTOMER SERVICE SYSTEMS**

FOR ADDITIONAL PRODUCT INFORMATION OR COPIES OF DRAWINGS AND TECHNICAL DOCUMENTS	PRODUCT INFORMATION CENTER 1-800-522-6752
FOR APPLICATION TOOLING INFORMATION	TOOLING ASSISTANCE CENTER 1-800-722-1111
FOR ORDER ENTRY	1-800-526-5142

MAX RECOMMENDED OPERATING
TEMPERATURE:
105°C MAX

VOLTAGE RATING:
300 V MAX

WIRE CROSS SECTIONAL AREA RANGE:
0.26-1.65mm² [509-3,260] CIR MILS
SOLID OR STRANDED

THIS DRAWING IS A CONTROLLED DOCUMENT FOR
AMP INCORPORATED. IT IS SUBJECT TO CHANGE
AND THE CONTROLLING ENGINEERING ORGANIZATION
SHOULD BE CONTACTED FOR THE LATEST REVISION.

MILITARY P/N AND CLASS	QUANTITY	LOOSE PIECE	36254
DO NOT SCALE PRINT. UNLESS SPECIFIED DIMENSIONS IN mm [INCHES] TOLERANCES ON: 2 PLC DEC ± 0.20 [0.008] 3 PLC DEC ± - ANGLES ± -	DR 02/11/93 DK SCHRUM CHK 4/28/93 RE HERSEY APPD 4/28/93 ML ELLIS APPD 4/28/93 M BARNABA PRODUCT SPEC UL 486A APPLICATION SPEC NOT AVAILABLE WEIGHT -	PACKAGE TYPE	PART NO
MATERIAL COPPER ASTM B-152 SLEEVE, RED NYLON	FINISH TIN PLATE PER MIL-T-10727	AMP AMP Incorporated Harrisburg, PA 17105-3608	NAME TERMINAL, RING TONGUE, PIDG™, WIRE SIZE, 22-16 AWG
SIZE	CAGE CODE	DRAWING NO	
B	00779	C-36254	
SCALE	4:1	SHEET	1 OF 1